

# Document made available under the Patent Cooperation Treaty (PCT)

International application number: PCT/IL05/000140

International filing date: 04 February 2005 (04.02.2005)

Document type: Certified copy of priority document

Document details: Country/Office: US  
Number: 60/566,078  
Filing date: 29 April 2004 (29.04.2004)

Date of receipt at the International Bureau: 09 May 2005 (09.05.2005)

Remark: Priority document submitted or transmitted to the International Bureau in compliance with Rule 17.1(a) or (b)



World Intellectual Property Organization (WIPO) - Geneva, Switzerland  
Organisation Mondiale de la Propriété Intellectuelle (OMPI) - Genève, Suisse

20 APR 2005

PA 1284533

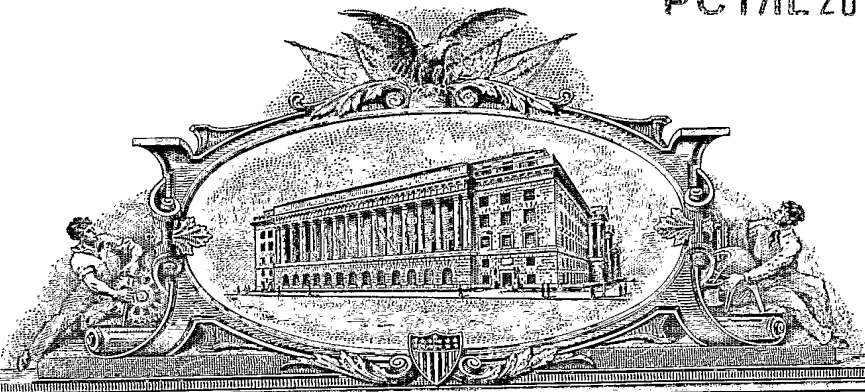

**THE UNITED STATES OF AMERICA**

**TO ALL TO WHOM THESE PRESENTS SHALL COME:**

**UNITED STATES DEPARTMENT OF COMMERCE**

**United States Patent and Trademark Office**

**February 14, 2005**

**THIS IS TO CERTIFY THAT ANNEXED HERETO IS A TRUE COPY FROM THE RECORDS OF THE UNITED STATES PATENT AND TRADEMARK OFFICE OF THOSE PAPERS OF THE BELOW IDENTIFIED PATENT APPLICATION THAT MET THE REQUIREMENTS TO BE GRANTED A FILING DATE UNDER 35 USC 111.**

**APPLICATION NUMBER: 60/566,078**

**FILING DATE: April 29, 2004**

**By Authority of the  
COMMISSIONER OF PATENTS AND TRADEMARKS**

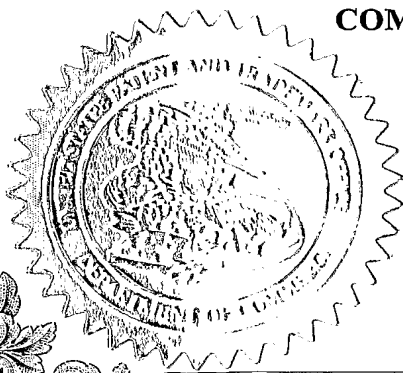

*P. R. Grant*  
**P. R. GRANT**  
Certifying Officer

16698 U.S. PTO

2264 U.S. PTO 60/566078



Please type a plus sign (+) inside this box

PTO/SB/16 (5-03) Approved for use through 4/30/2003. OMB 0651-0032 U.S. Patent and Trademark Office; U.S. DEPARTMENT OF COMMERCE Under the Paperwork Reduction Act of 1995, no persons are required to respond to a collection of information unless it displays a valid OMB control number.

**PROVISIONAL APPLICATION FOR PATENT COVER SHEET**  
This is a request for filing a PROVISIONAL APPLICATION FOR PATENT under 37 CFR 1.53(c).

INVENTOR(S)					
Given Name (first and middle [if any])		Family Name or Surname		Residence (City and either State or Foreign Country)	
Omer Ernesto		EINAV KORENMAN		Moshav Kfar-Monash, Israel Raanana, Israel	
<input type="checkbox"/> Additional inventors are being named on the _____ separately numbered sheets attached hereto					
TITLE OF THE INVENTION (280 characters max)					
NEUROMUSCULAR STIMULATION					
Direct all correspondence to:			CORRESPONDENCE ADDRESS		
<input type="checkbox"/> Customer Number <input type="text"/>			<input type="checkbox"/> Place Customer Number Bar Code Label here		
OR			Type Customer Number here		
<input checked="" type="checkbox"/> Firm or Individual Name	Roy N. Envall, Jr.				
Address	c/o Anthony Castorina				
Address	2001 Jefferson Davis Highway, Suite 207				
City	Arlington	State	VA	ZIP	22202
Country	U.S.A.	Telephone	(703) 415-1581	Fax	(703) 415-4864
ENCLOSED APPLICATION PARTS (check all that apply)					
<input checked="" type="checkbox"/> Specification	Number of Pages	18	<input type="checkbox"/> CD(s), Number	<input type="text"/>	
<input checked="" type="checkbox"/> Drawing(s)	Number of Sheets	5	<input type="checkbox"/> Other (specify)	<input type="text"/>	
<input type="checkbox"/> Application Data Sheet. See 37 CFR 1.76					
METHOD OF PAYMENT OF FILING FEES FOR THIS PROVISIONAL APPLICATION FOR PATENT (check one)					
<input checked="" type="checkbox"/>	Applicant claims small entity status. See 37 CFR 1.27.				FILING FEE AMOUNT (\$)
<input type="checkbox"/>	A check or money order is enclosed to cover the filing fees				
<input checked="" type="checkbox"/>	The Director is hereby authorized to charge filing fees or credit any overpayment to Deposit Account Number <input type="text" value="03-3419"/>				<input type="text" value="\$80.00"/>
<input type="checkbox"/>	Payment by credit card. Form PTO-2038 is attached.				
The invention was made by an agency of the United States Government or under a contract with an agency of the United States Government.					
<input checked="" type="checkbox"/>	No.				
<input type="checkbox"/>	Yes, the name of the U.S. Government agency and the Government contract number are: _____				

Respectfully submitted,

SIGNATURE

TYPED or PRINTED NAME Maier Fenster

(703) 415-1581

TELEPHONE

Date 04/29/2004

REGISTRATION NO.

41,016

(if appropriate) Docket Number:

414/04031

**USE ONLY FOR FILING A PROVISIONAL APPLICATION FOR PATENT**

This collection of information is required by 37 CFR 1.51. The information is used by the public to file (and by the PTO to process) a provisional application. Confidentiality is governed by 35 U.S.C. 122 and 37 CFR 1.14. This collection is estimated to take 8 hours to complete, including gathering, preparing, and submitting the complete provisional application to the PTO. Time will vary depending upon the individual case. Any comments on the amount of time you require to complete this form and/or suggestions for reducing this burden, should be sent to the Chief Information Officer, U.S. Patent and Trademark Office, U.S. Department of Commerce, P.O. Box 1450, Alexandria, VA 22313-1450. DO NOT SEND FEES OR COMPLETED FORMS TO THIS ADDRESS. SEND TO: Mail Stop Provisional Application, Commissioner for Patents, P.O. Box 1450, Alexandria, VA 22313-1450.

If you need assistance in completing the form, call 1-800-PTO-9199 and select option 2.

P1MALL/REV06

414/04031

## NEUROMUSCULAR STIMULATION

### RELATED APPLICATIONS

This application claims the benefit under §119(e) of U.S. Provisional Application No. 60/542,022, filed on February 5, 2004, by Omer Einav et al., and  
5 U.S. Provisional Application filed on even date, titled "Fine Motor Control Rehabilitation", attorney docket number 414/04032, the disclosure of both applications are incorporated herein by reference.

### FIELD OF THE INVENTION

The field of the invention is devices for rehabilitation of patients with motor  
10 control problems.

### BACKGROUND OF THE INVENTION

Voluntary muscle movement is caused by electrical impulses which originate in the somato-motor cortex of the brain. A neuron in the somato-motor cortex sends electrical signals to a motor neuron in the spinal cord, which in turn sends electrical  
15 signals which stimulate the contraction of muscle fibers, producing movement. All of the muscle fibers which are stimulated by a given motor neuron are called a "motor unit." Each muscle fiber exhibits an electrical potential across its cell membrane, which changes when the muscle contracts.

In electromyography (EMG), the difference in potential on the surface of the  
20 skin is measured between the center and the ends of a muscle, which gives a measure of the number of contracting muscle fibers. EMG is regularly used to diagnose a variety of medical conditions in patients, as well as in healthy subjects for research on muscle function.

In stroke patients with damage to their somato-motor cortex, electrical signals  
25 are not generated for one or more muscles or parts of muscles, or do not reach those muscles, and normal contraction of those muscles is impossible. Often, residual EMG signals, too weak or too spread out to cause the muscles to contract, are still detectable.

Neuromuscular electrical stimulation (NMES) is used to produce contraction  
30 of a muscle which cannot contract normally in a stroke patient. NMES may stop spasticity in a muscle, and may prevent the muscle from atrophying. It is also known to turn NMES of a single muscle on or off in response to residual EMG signals detected from that muscle, thereby allowing the muscle to contract under the control of the patient.

414/04031

SUMMARY OF THE INVENTION

An aspect of an embodiment of the invention concerns applying NMES to a paretic arm, or any other part of the body with voluntary muscles, at an amplitude that would be too low to produce motion by itself, but which, in combination with nerve impulses arising in the patient's motor cortex, allow the arm or other body part to move, or to move more effectively than without the NMES. It does this, for example, by producing muscular feedback which helps to train the motor cortex to move that body part. In some embodiments, the NMES need not be very strong, or very precisely directed, in order to do this. Whenever this application refers to arms, it should be understood that any other body part, or combination of body parts, with voluntary muscles may be used instead. Optionally, EMG signals from the same arm, or from the corresponding muscles in the patient's other arm, or from the arm of another person, are used to determine the pattern of the NMES.

Another aspect of an embodiment of the invention concerns the use of EMG signals from one arm, optionally a healthy arm, undergoing voluntary motion, to determine a pattern of NMES to be applied to another, paretic arm. Optionally EMG signals from the paretic arm are also used, at least to determine the timing of the NMES. Optionally, the healthy arm is the other arm of the patient, and the patient tries to move both arms in synchrony, in a mirror symmetric pattern.

Optionally, for either of these embodiments of the invention, the EMG and NMES involve a coordinated sequence of contractions of more than one muscle, and/or a range of amplitudes for the NMES, rather than having the NMES either on or off for a single muscle.

By providing feedback, through the kinesthetic sense, of a coordinated sequence of muscle contractions, the patient's nervous system may be encouraged to utilize alternative undamaged pathways for nerve impulses, or alternative locations in the motor cortex, and the patient can learn to move his arm more effectively on his own. This may be especially true if the NMES is coordinated with the weak nerve impulses that the patient produces on his own, as measured by the EMG.

Optionally, a device, for example a robotic arm, which monitors and displays the movement of the arm, is used for the paretic arm, and optionally also for the healthy arm if one is used. Information about the movement of the arm can provide further feedback to the patient, as well as feedback for controlling the NMES, and feedback to a physical therapist who is monitoring the progress of the patient's

414/04031

rehabilitation. A robotic arm or similar device can also mechanically move the paretic arm, complementing the NMES by providing a different kind of kinesthetic feedback. A robotic arm can also exert a force working against the muscle, providing a way to strengthen the arm as well as to measure progress in strengthening the arm.

#### BRIEF DESCRIPTION OF THE DRAWINGS

Exemplary embodiments of the invention are described in the following sections with reference to the drawings. The drawings are generally not to scale and the same or similar reference numbers are used for the same or related features on different drawings.

Fig. 1 is a schematic drawing of a healthy arm with EMG electrodes, an EMG unit, a signal processing unit, an NMES unit, and a paretic arm with NMES and EMG electrodes, according to an exemplary embodiment of the invention;

Fig. 2 shows plots of a raw EMG signal, rectified signal, smoothed rms signal, according to an exemplary embodiment of the invention;

Fig. 3 is a schematic drawing of an arm attached to a robot arm, according to an exemplary embodiment of the invention;

Fig. 4 is a schematic drawing of a paretic arm with NMES electrodes and EMG electrodes, nerve signals from brain, and a signal processing unit, according to a different exemplary embodiment of the invention than Fig. 1; and

Figs. 5A-5G are a time sequence of plots of EMG signals from flexor and extensor signals, at different times during rehabilitation, according to an exemplary embodiment of the invention.

#### DETAILED DESCRIPTION OF EXEMPLARY EMBODIMENTS

Fig. 1 shows an apparatus for applying NMES to several muscles of a paretic arm, guided by EMG signals from the corresponding muscles of a healthy arm. Healthy arm 102, belonging either to the patient with the paretic arm or to someone else, has EMG electrodes attached to the skin. The person whose arm it is moves the arm voluntarily in a particular pattern, which generates a certain time-dependent pattern of EMG voltages in the muscles. There are optionally four EMG channels, one channel measuring EMG signals from each of four muscles: the biceps, the triceps, the flexors, and the extensors. Each channel uses three electrodes, two recording signals from near each end of the muscle, and one reference electrode in the middle. Thus, electrodes 104 measure the biceps, electrodes 106 measure the triceps, electrodes 108 measure the flexors, and electrodes 110 measure the extensors. When

414/04031

the arm is moved voluntarily, these electrodes transmit the EMG signals corresponding to the pattern of muscle contractions producing that movement of the arm, via cable bundles 112, 114, 116, and 118, to an EMG device 120. The EMG device, or a separate controller, does preliminary processing of the EMG signals, for example amplifying them, digitizing them, and/or recording them.

The EMG signals are then transmitted, via a cable 122, to a controller 124, which is, for example, a personal computer, or comprises special dedicated hardware. The controller optionally further processes the EMG signals, for example filtering them, rectifying them, smoothing them, changing the timing, or cutting and pasting parts of a sequence in a different order. The signal processing is optionally done automatically, or is partly or entirely under the control the physical therapist. Fig. 2 shows a plot of a filtered raw EMG signal 202 from one channel, a rectified signal 204, and a smoothed rectified signal 206, in which the root mean square of the signal is calculated in each of a sequence of time intervals, or example every 10 milliseconds. The smoothed rectified signal is a measure of the overall degree of contraction of the muscle or section of the muscle measured by that channel, while eliminating high frequency noise associated with the changes in potential of individual muscle fibers. Optionally, the smoothed rectified EMG signal is averaged over many repetitions of the same pattern of movement. Optionally, the EMG sensors add up or average the EMG signals coming from several different sections of the muscle, or this is done by the signal processing. Optionally, one or more of the parameters of the signal processing are controlled by the therapist.

Controller 124 also controls NMES device 126, via cable 128. Optionally, controller 124 commands NMES device to produce NMES signals in each of four channels. The signals in the four channels travel through cables 130, 132, 134, and 136, to electrodes 138, 140, 142, and 144, which respectively stimulate the biceps, triceps, flexors, and extensors on the patient's parctic arm 146. Optionally, the NMES signals in each channel are given a time-dependent amplitude which will produce the same movement in the parctic arm as was performed by the healthy arm. This is done, for example, by making the signal strength in each NMES channel depend on the processed signal amplitude from a corresponding one of the four EMG channels. For example, the NMES signal is proportional to the processed EMG signal amplitude, or is a fixed monotonic function of the processed EMG signal amplitude, for the corresponding channel.

414/04031

Optionally, the NMES signal depends also on the EMG signal from one or more other channels. For example, because the biceps and triceps work against each other, the NMES signals controlling the biceps and triceps, optionally depend on a linear combination of the EMG signal from the biceps and the EMG signal from the triceps, with a negative coefficient for the EMG signal from the triceps. If the linear combination is positive, only the biceps is stimulated, and if the linear combination is negative, only the triceps is stimulated. A similar method is optionally used for the flexors and extensors which also work against each other.

Optionally, the NMES signals are based not directly on the EMG signals from the corresponding muscles, but are modified to produce motion that is reversed in some way from the motion associated with the EMG signals. For example, if the EMG signals come from a left arm and the NMES signals are applied to a right arm, then optionally the NMES signals are changed to produce motion in the right arm that is the same as the motion of the left arm, rather than a mirror image of it, as would occur if the corresponding muscles in the two arms were to contract at the same time. Alternatively or additionally, whether or not the two arms are a left arm and a right arm, if the motion of the healthy arm is cyclical, then the NMES signals are changed to produce motion in the paretic arm that is 180 degrees out of phase from the motion of the healthy arm. Such a modification in the NMES signals might be particularly useful to use for the left and right legs, for example, in a patient who needs to relearn how to walk.

Optionally, there are also EMG electrodes 148, 150, 152, and 154, attached to the paretic arm. These sensors send signals along cables 156, 158, 160 and 162, respectively, to four additional channels of EMG device 120, which thus has a total of eight channels. These additional EMG signals are processed by the EMG device and by controller 124, similar to the processing of the EMG signals from healthy arm 102. Optionally, the EMG signals from paretic arm 146 are also used by controller 124 in controlling the NMES signals. The EMG signals in paretic arm 146 may arise because the sensory-motor cortex of the patient is still capable of producing weak nerve impulses in paretic arm 146, even if these nerve impulses are too weak to cause the paretic arm to move. By timing the NMES signals to the corresponding EMG signals in the paretic arm, the paretic arm can move in response to the attempts of the patient to move it, providing kinesthetic feedback to the patient. Alternatively or additionally,



414/04031

EMG signals in paretic arm 146 may be induced by moving paretic arm 146 passively, for example by a robot arm as discussed below in describing Fig. 3.

Optionally, controller 124 also uses other information in controlling the strength of the NMES signals. For example, the healthy arm has a sensor 164, for example a strain sensor, which measures the degree of bending of the elbow, and a sensor 166 which measures the degree of extension of the fingers, while the paretic arm has similar sensors 168 and 170. The sensors feed into a unit 172 which processes the sensor data to determine the bending of the arm and fingers, and this information is conveyed, for example by cable 174, to controller 124. Optionally, unit 172 and controller 124 are part of a single control unit. Optionally, sensors are used only with one of the arms. Optionally there are other sensors which measure other aspects of the arm and hand position, particularly if EMG and NMES is used with additional muscles. A variety of other types of sensors are additionally or alternatively used for measuring the arm or hand position, for example the arm is fitted to a robot arm which has such sensors to measure its own state, as shown in Fig. 3 which will be described below. Or, LEDs are attached to key points on the arm and hand and their location tracked with a video camera, or magnetic field sensors are attached to key points on the arm and hand, and an external magnetic field and/or field gradient imposed. Other methods will be apparent to those skilled in the art of sensing the position and orientation of body parts.

The position of the paretic arm can be used, for example, as negative feedback to the NMES signals. During the course of rehabilitation, as the patient's own nerve impulses become stronger and/or more effective, for example distinguishing better between antagonistic pairs of muscles, the NMES signal can be reduced while producing the same arm motion. This kind of feedback can also be used within a given rehabilitation session. For example, if the patient is momentarily having trouble continuing to move his arm, the NMES amplitude is momentarily increased, until the patient is able to start moving his arm again. Optionally, in this case, the controller distinguishes between the patient simply resting, and the patient trying unsuccessfully to move his arm, for example by looking at EMG signal levels in the paretic arm.

The position of the healthy arm can be used, for example, to supplement the EMG signals from the healthy arm, as a measure of the degree of contraction of the muscles in the healthy arm. Alternatively or additionally, the data on position of both arms can be used to monitor the progress of the rehabilitation of the patient.

414/04031

Fig. 3 shows an arm 302, which could be either the healthy arm or the paretic arm in Fig. 1, attached to a robot arm 300. The upper arm is held by a holder 304, and the lower arm is held by a holder 306. Upper arm holder 304 is attached to an extendable rod 308, which is connected to a controllable ball joint 310, and similarly  
5 lower arm holder 306 is attached to an extendable rod 312, which is connected to a controllable ball joint 314. Ball joints 310 and 314 are connected to each other with a rigid connector 316. The ball joints and extendable rods include both actuators and sensors, for all their degrees of freedom, in this case two degrees of freedom for each ball joint, and one degree of freedom for each extendable rod. The sensors can sense  
10 the degree of bending of the elbow of arm 302, and the actuators can apply force to bend or unbend the elbow, and/or to resist bending or unbending of the elbow by the patient. Optionally, the actuators and sensors have more or fewer degrees of freedom, depending for example on which muscles are being rehabilitated, and optionally the robot arm is attached to additional points on arm 302, for example to different points  
15 on the wrist, hand, and fingers. Signals from the sensors and to the actuators are processed by a robot arm control box, not shown in Fig. 3.

The robot arm optionally is used in the same way as sensors 164, 166, 168 and 170 in Fig. 1. In addition, the fact that the robot arm can move in a controlled way under its own power means that it can supplement the NMES, in providing kinesthetic  
20 feedback for the patient, if used with the paretic arm. The robot arm provides a different kind of kinesthetic feedback than NMES provides, since it moves the paretic arm without causing muscles to contract under their own power, and both types of feedback are potentially useful in rehabilitation. For example, NMES may not be able to produce a smooth and accurate motion by itself, and robot arm can help to correct  
25 and smooth the motion induced by NMES.

Optionally, both the passive and active modes of the robot arm are combined with the NMES. Movement generated by the robot arm is assisted by contraction of the muscles by NMES. When the patient moves the robot arm in an active way, the NMES signals are adjusted correspondingly.

30 Fig. 4 shows an arrangement according to another exemplary embodiment of the invention, in which only a paretic arm 146 is used. As in Fig. 1, there are EMG electrodes 148, 150, 152 and 154, attached respectively to the biceps, triceps, flexors and extensors of the paretic arm, three electrodes for each muscle, and the EMG signals are conveyed along cables 156, 158, 160, and 162, to an EMG device 120,

414/04031

which, after preliminary processing, transmits the signals to controller 124. As in Fig. 1, controller 124 uses the EMG signals in determining the amplitude and timing of NMES signals transmitted by NMES device 126, which stimulate the biceps, triceps, flexors and extensors of paretic arm 146 through NMES electrodes 138, 140, 142, and 5 144.

The NMES signals transmitted by NMES device 126 in Fig. 4 are not strong enough, in themselves, to cause paretic arm 146 to move significantly, and this is optionally also true in Fig. 1. But the NMES signals, together with the patient's own nerve impulses, are strong enough to cause the arm to move. Thus, the paretic arm 10 only moves when the patient tries to move it, and the kinesthetic feedback provided by the motion further encourages the development of alternate pathways for nerve impulses in the patient, or alternate locations in the motor cortex to originate nerve impulses to the same muscles, eventually enabling the patient to move the paretic arm by himself. This may be particularly useful when the motion involves a coordinated 15 sequence of contractions of more than one muscle. Optionally, in the course of rehabilitation, the NMES signal is lowered, as less NMES signal is needed in order to allow the patient to move the paretic arm.

Optionally, in the absence of nerve impulses from the patient's motor cortex, the NMES signals are between 100% and 120% of the amplitude needed to produce 20 motion for an average healthy subject, or for an average paretic patient, or they are adjusted to that level for a particular patient. Alternatively, they are between 120% and 140% of that amplitude for any of these people, or between 80% and 100%, or between 60% and 80%, or less than 60%. Optionally, for any of these people, the NMES signals are between 100% and 120% of the level needed to produce motion in 25 the presence of nerve impulses from the motor cortex when the person makes an effort to move, or between 120% and 140%, or between 140% and 200%, or greater than 200%.

Optionally, the NMES is targeted to a part of the muscle with at least as much spatial precision as an average healthy subject is able to achieve when voluntarily 30 directing nerve impulses to that muscle. Alternatively, the NMES is targeted with less than this much precision, but with at least half this much precision, or with less than half this much precision, but at least one quarter this much precision, or with less than one quarter this much precision.

414/04031

Characteristics of the procedure illustrated in Figs. 1 and 4 can be varied to adapt to the needs of the patient, in order to facilitate rehabilitation. Several examples are given below.

The EMG and NMES need not use the four muscles shown being used in Figs. 1 and 4, but could include more muscles, or fewer muscles. Optionally, only the biceps and triceps are used initially. Then, once the patient has gained some ability to use the biceps and triceps effectively, the flexors and extensors are added to the EMG and NMES channels. These four muscles are basic to gross control of the arm. Later, individual fingers are added, and/or other wrist and hand motions, to improve fine motor control. For rehabilitation of body parts other than the arm, of course, other groups of muscles are selected.

The amplitude of NMES optionally varies depending on feedback from various sources, and depending on the immediate goal of the rehabilitation program. As mentioned previously, the NMES signal is optionally decreased as the patient recovers the ability to generate nerve impulses and move his muscles by himself. Alternatively, if the immediate goal is the strengthening of atrophied muscles, the amplitude of NMES is optionally increased as the muscle gets stronger, and can benefit from more strenuous exercise. In this case, the arm is optionally made to move against a restraining force, for example a weight or a robotic arm, which is increased as the muscle gets stronger, so a stronger NMES signal is required in order to move the arm by the same amount.

In addition to using kinesthetic feedback to encourage the development of alternative pathways for nerve impulses, as discussed above, other kinds of feedback are optionally used to help the patient learn how to control his muscles more effectively. For example, seeing the movement of the arm, when his nerve impulses are supplemented by NMES stimulation, can help the patient adjust his efforts to move his arm. Similarly, such feedback for conscious learning by the patient can be provided by a device, such as the robot arm in Fig. 3, which measures and records the motion of the arm, and by the processed EMG signals. For example, the patient can try to make the EMG signals from the paretic arm more closely resemble the EMG signals generated by the healthy arm when it is performing the desired movement, or he can try to make the EMG signals from the paretic arm more closely resemble some template, perhaps developed from examining recorded EMG signals from the healthy arm, or from paretic arms of other patients who have undergone similar rehabilitation.

414/04031

In the arrangement shown in Fig. 1, if the patient's other arm is used as the healthy arm, then optionally the patient tries to move both arms synchronously, in mirror image movements. The NMES signals, optionally based on the EMG signals of the healthy arm, allow the paretic arm to move, and since the patient is attempting to move both arms in synchrony, he receives kinesthetic feedback from the paretic arm, which helps promote the development of alternate pathways for nerve impulses.

Optionally, the NMES signals are adapted to the capability of the paretic arm. For example, if the muscles in the paretic arm are incapable of responding as rapidly as normal to the NMES, then the NMES signals are optionally slowed down, or high frequency components are reduced or removed. As the muscles recover the capability of more rapid response, the NMES signals are sped up again. The speed of the NMES signals is either adjusted automatically, in response to sensor data on movement of the paretic arm, or manually by the therapist, optionally using such sensor data to evaluate the patient. If a robotic arm is used in coordination with NMES to help move the paretic arm, the motion of the robotic arm is optionally slowed down together with the NMES. Even if the robotic arm is used to help move the paretic arm without NMES, the motion of the robotic arm is optionally slowed down if, for example, this will help the patient to make a greater contribution to the motion with his own nerve impulses, or will be useful for some other reason in rehabilitation.

Figs. 5A through 5G illustrate a procedure for rehabilitating a patient who has a problem that is common following a stroke in the somatomotor cortex—the failure of the patient's nerve impulses to distinguish adequately between two muscles that form an antagonistic pair, such as the biceps and triceps, or the flexors and extensors. As shown in Fig. 5A, the EMG signal 402 from the flexors, and signal 404 from the extensors, when the patient attempts to open and close her hand, are strong enough to cause both muscles to contract, since they are above threshold level 406. But both muscles contract at the same time, so that they work against each other, and the hand exhibits very little movement. First, the patient learns to decrease the overall activity of both the flexors and extensors, below the threshold for contraction, as shown progressively in Figs. 5B, 5C, and 5D. Then, as shown in Figs. 5E, 5F, and 5G, the patient is taught to increase the activity of the extensors, while keeping the flexors relaxed. This is done, for example, by applying NMES to the extensors, increasing kinesthetic feedback, when patient tries to contract the extensors.

414/04031

To summarize, we list below some of the rehabilitation methods that can be used, including those discussed.

- 1) Record EMG in healthy arm and apply similar pattern of NMES to paretic arm, in real time or not.
- 5 2) Adjust NMES amplitude to supplement nerve impulses in paretic arm, as measured by EMG in paretic arm.
- 3) Target NMES to sections of paretic arm where EMG is weak.
- 4) Slow down NMES to adapt to slow response time of paretic arm.
- 5) Have patient move both arms together, in mirror image, while applying NMES  
10 based on EMG in healthy arm.
- 6) Have patient move both arms together not in a mirror image, and/or in a cyclical motion 180 degrees out of phase, while applying NMES based on (but modified from) EMG in healthy arm.
- 7) Base NMES on average EMG over many repetitions of movement by healthy arm.
- 15 8) Sense position of paretic arm and use negative feedback for NMES; optionally use EMG of paretic arm to distinguish inability to move arm from intentional resting.
- 9) Record sensed position of healthy arm as a function of time while recording EMG signals, then apply corresponding NMES to paretic arm when paretic arm is in a corresponding position.
- 20 10) Use robotic arm to move healthy arm in a desired pattern, detect the resulting EMG signals generated passively in the healthy arm, and use them as a basis for NMES applied to paretic arm to produce corresponding motion.
- 11) Use robotic arm and/or NMES to move or assist moving paretic arm, matching to measured position of healthy arm.
- 25 12) Use robot arm to measure resistance of paretic arm to motion, thereby determining whether failure of paretic arm to move is due to failure of muscle to contract, or failure to differentiate between antagonistic pairs of muscles; optionally adjust NMES accordingly.
- 13) Use robotic arm, with or without NMES, to assist moving paretic arm, slowing  
30 down robotic arm to match capability of paretic arm.
- 14) Use robotic arm to work against muscles of paretic arm, with or without NMES, optionally adapting force to capability of paretic arm.
- 15) Use EMG of paretic arm to teach patient to better control paretic arm, optionally including better differentiating between antagonistic pairs of muscles.

414/04031

As used herein, a "position" of an arm or another body part may include not just the spatial location of a particular portion of the arm or body part, but any other information needed to specify its spatial state, including, for example, how much it is bent at the elbow, how much the forearm is twisted, how much the wrist is bent, etc.

5           The invention has been described in the context of the best mode for carrying it out. It should be understood that not all features shown in the drawing or described in the associated text may be present in an actual device, in accordance with some embodiments of the invention. Furthermore, variations on the method and apparatus shown are included within the scope of the invention, which is limited only by the  
10       claims. Also, features of one embodiment may be provided in conjunction with features of a different embodiment of the invention. As used herein, the terms "have", "include" and "comprise" or their conjugates mean "including but not limited to."

414/04031

CLAIMS

1. Apparatus for rehabilitating a patient who has a paretic body part, the apparatus comprising:
  - 5 a) at least one electromyography (EMG) sensor adapted to being applied to a voluntary muscle of a healthy body part of the same type as the paretic body part, which at least one sensor produces at least one EMG signal;
  - b) a neuromuscular electrical stimulation (NMES) device adapted to stimulating at least one voluntary muscle of the paretic body part; and
  - 10 c) a controller which controls the NMES device, making the amplitude of stimulation of the paretic body part at least partly dependent on the EMG signal from the healthy body part.
  
2. Apparatus according to claim 1, wherein the at least one muscles of the  
15 healthy body part correspond to the at least one muscles of the paretic body part.
  
3. Apparatus according to claim 2, wherein the controller is configured so that the NMES stimulates the paretic body part to make a movement corresponding to a movement made by the healthy body part when the EMG signals are sensed.  
20
  
4. Apparatus according to claim 3, wherein the controller is configured so that the amplitude of stimulation of at least one of the at least one muscles of the paretic body part increases when the EMG signal from the corresponding muscle of the healthy body part increases at a corresponding time in the movement of the healthy  
25 body part.
  
5. Apparatus according to claim 3 or claim 4, wherein the at least one muscles of the paretic body part comprise an antagonistic pair of muscles, and the controller is configured so that the amplitude of stimulation of one muscle of the antagonistic pair  
30 of muscles decreases when the EMG signal from the muscle in the healthy body part corresponding to the other muscle of the antagonistic pair of muscles increases at a corresponding time in the movement of the healthy body part.



414/04031

6. Apparatus according to any of the preceding claims, wherein one or both of the controller and the NMES device are configured so that the stimulation amplitude is not high enough to cause the stimulated muscle to contract in the absence of nerve impulses from the patient's brain, but is high enough to cause the muscle to contract  
5 in the presence of nerve impulses from the patient's brain, for at least some patients who cannot move said body part by themselves.
7. Apparatus according to any of the preceding claims, wherein the at least one EMG sensor comprises a plurality of EMG sensors, each EMG sensor adapted to  
10 being applied to a different muscle or muscle part of the healthy body part.
8. Apparatus according to claim 7, wherein each EMG sensor produces a separate EMG signal.
- 15 9. Apparatus according to claim 8, wherein the NMES device is adapted to independently stimulating a plurality of muscles or muscle parts of the paretic body part.
10. Apparatus according to claim 9, wherein said plurality of muscles or muscle  
20 parts of the paretic body part correspond to the muscles or muscle parts of the healthy body part to which the plurality of EMG sensors are adapted to being applied.
11. Apparatus according to claim 10, wherein the controller is configured so that  
25 amplitude of NMES stimulation of said plurality of muscles or muscle parts of the paretic body part is at least partly dependent on the EMG signals from the plurality of EMG sensors.
12. Apparatus according to claim 11, wherein the controller is configured so that  
30 the amplitude of NMES stimulation of each of said plurality of muscles or muscle parts depends at least partly on the EMG signal from the corresponding muscle or muscle part.
13. Apparatus according to any of the preceding claims, wherein the paretic body part is a body part that comes in pairs.

414/04031

14. Apparatus according to claim 13, wherein the paretic body part is an arm.
15. Apparatus according to claim 13, wherein the paretic body part is a leg.
- 5
16. Apparatus according to any of claims 13-15, wherein the healthy body part belongs to the patient.
17. Apparatus according to any of claims 13-15, wherein the healthy body part  
10 does not belong to the patient.
18. Apparatus according to any of the preceding claims, wherein the controller makes the stimulation amplitude at least partly dependent on a processed form of the EMG signal.
- 15
19. Apparatus according to claim 18, wherein the processed form of the EMG signal is stretched out in time from the EMG signal.
20. Apparatus according to claim 18 or claim 19, wherein the processed form of  
20 the EMG signal corresponds to an EMG signal that would be produced by a movement of the healthy body part that is a mirror image of a movement that the healthy part was undergoing when the EMG signal was generated.
21. Apparatus according to any of claims 18-20, wherein the processed form of  
25 the EMG signal is time delayed from the EMG signal.
22. Apparatus according to any of the preceding claims, also including a first position sensing device which monitors a position of the healthy body part.
- 30 23. Apparatus according to claim 22, also including a first actuating device which mechanically changes the position of the healthy body part.
24. Apparatus according to any of the preceding claims, also including a second position sensing device which monitors a position of the paretic body part.

414/04031

25. Apparatus according to claim 24, also including a second actuating device which mechanically changes the position of the paretic body part.
- 5 26. Apparatus adapted for rehabilitating a class of patients who have a paretic body part, the apparatus comprising a neuromuscular electrical stimulation (NMES) device adapted to stimulating at least one voluntary muscle in the paretic body, wherein the amplitude of stimulation is not sufficient by itself to cause contraction of said muscle, but the amplitude of stimulation is sufficient to cause contraction of said  
10 muscle when a patient in said class attempts to move the body part at the same time.
27. Apparatus according to any of the preceding claims, also including at least one paretic EMG sensor adapted for applying to a voluntary muscle of the paretic body part, which at least one paretic EMG sensor produces at least one paretic EMG signal.  
15
28. Apparatus according to claim 27, wherein the controller makes the amplitude of stimulation of the paretic body part at least partly dependent on the at least one paretic EMG signal.
- 20 29. Apparatus according to claim 28, wherein the at least one paretic EMG sensors adapted for applying to the paretic body part comprise a plurality of paretic EMG sensors, each adapted for applying to a different muscle or muscle part of the paretic body part, and each producing a separate paretic EMG signal.
- 25 30. Apparatus according to claim 29, wherein the NMES device is adapted to stimulate the muscles or muscle parts of the paretic body that the paretic EMG sensors are adapted for being applied to, and the controller is configured to make the amplitude of stimulation of each muscle or muscle part depend at least partly on the paretic EMG signal from that muscle or muscle part.  
30
31. A method of rehabilitating a patient who has a paretic body part, the method comprising:
- a) having the patient or another person move a healthy body part that is of the same type as the paretic body part;

414/04031

- b) detecting EMG signals from the healthy body part while it is being moved;  
and
- c) applying NMES to the paretic body part, at an amplitude that depends at least partly on the EMG signals.

5

32. A method according to claim 31, also including having the patient attempt to move the paretic body part, while the NMES is applied, in the same pattern of movement that the healthy body part is moved in while the EMG signals are detected.

- 10 33. A method according to claim 32, wherein detecting the EMG signals comprises detecting the EMG signals from a plurality of muscles or muscle parts of the healthy body part, and applying NMES comprises applying NMES to a plurality of muscles or muscle parts of the paretic body part corresponding to the plurality of muscles or muscle parts of the healthy body part.

15

34. A method according to claim 33, wherein the amplitude of NMES applied to each muscle or muscle part of the paretic body part during a time interval in the pattern of attempted movement of the paretic body part depends at least partly on the EMG signal detected from the corresponding muscle or muscle part of the healthy  
20 body, during a corresponding time interval in the pattern of movement of the healthy body part.

414/04031

ABSTRACT

Apparatus for rehabilitating a patient who has a paretic body part, the apparatus comprising:

- 5 a) at least one electromyography (EMG) sensor adapted to being applied to a voluntary muscle of a healthy body part of the same type as the paretic body part, which at least one sensor produces at least one EMG signal;
- b) a neuromuscular electrical stimulation (NMES) device adapted to stimulating at least one voluntary muscle of the paretic body part; and
- 10 c) a controller which controls the NMES device, making the amplitude of stimulation of the paretic body part at least partly dependent on the EMG signal from the healthy body part.

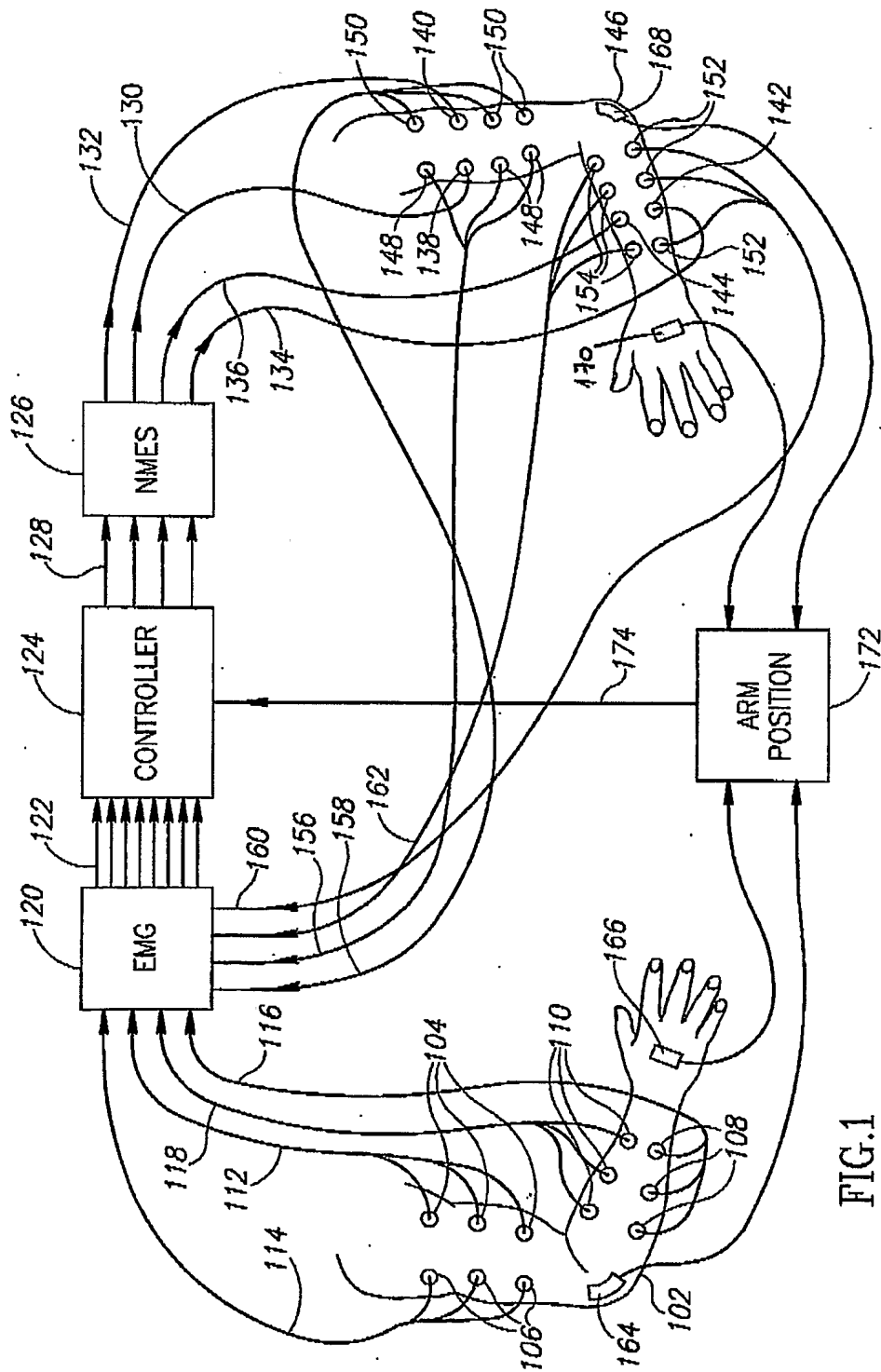

FIG.1

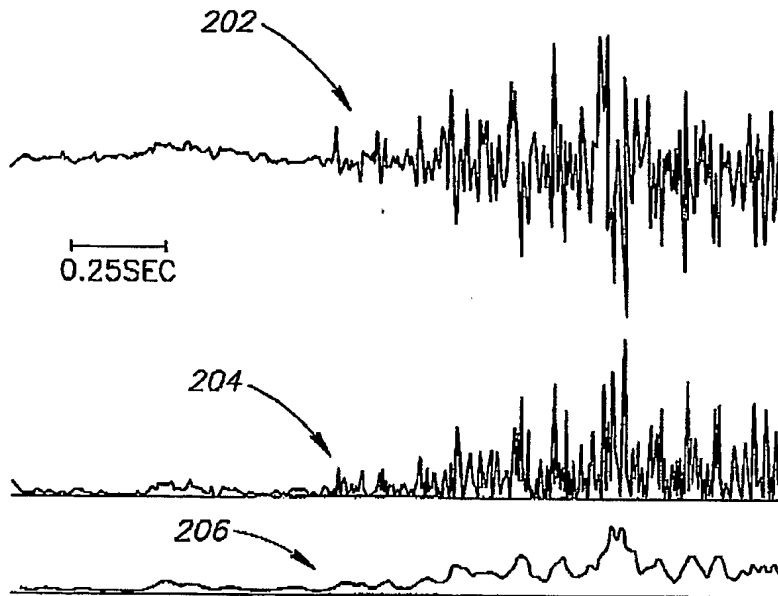

FIG. 2

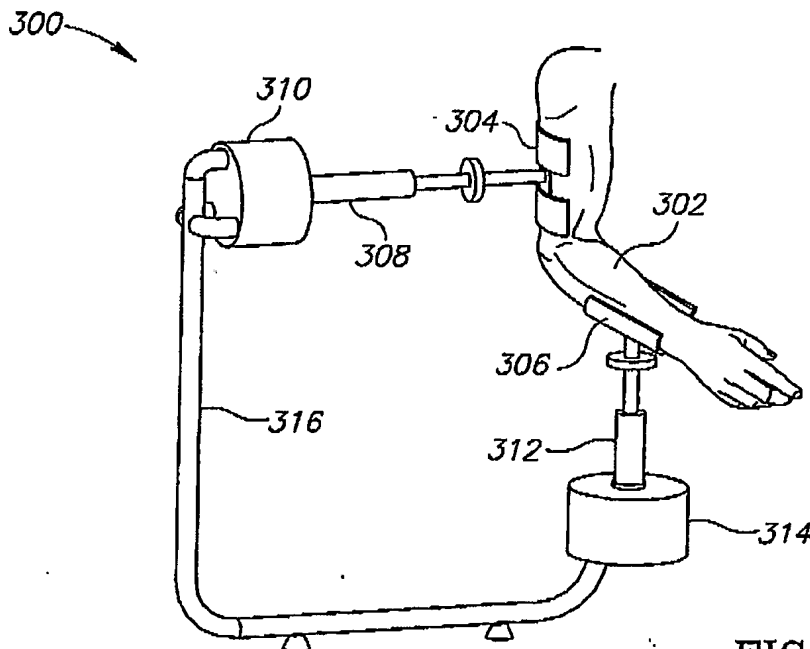

FIG. 3

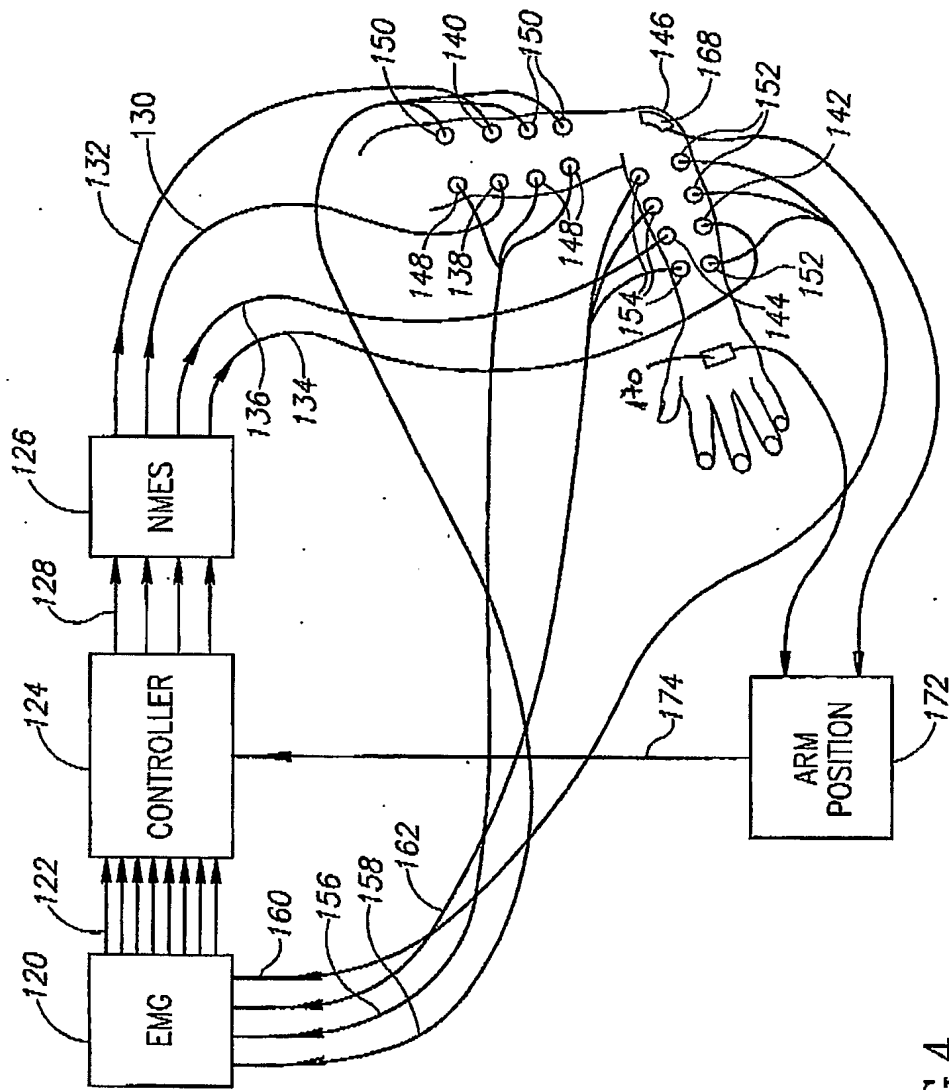

FIG. 4



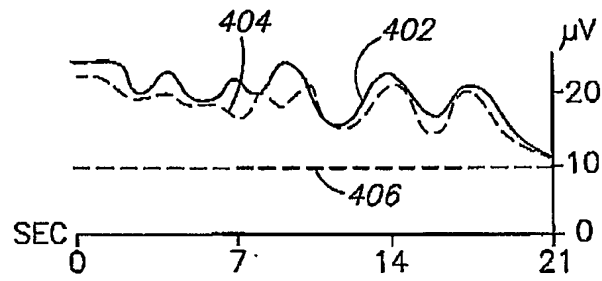

FIG. 5A

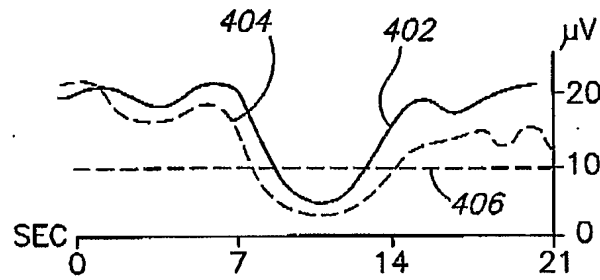

FIG. 5B

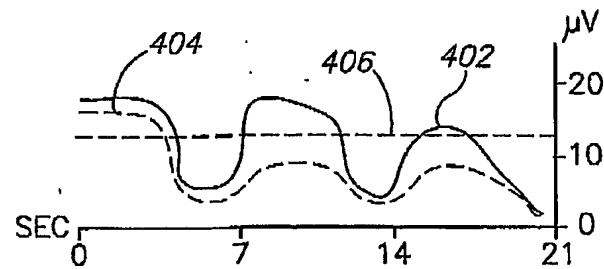

FIG. 5C

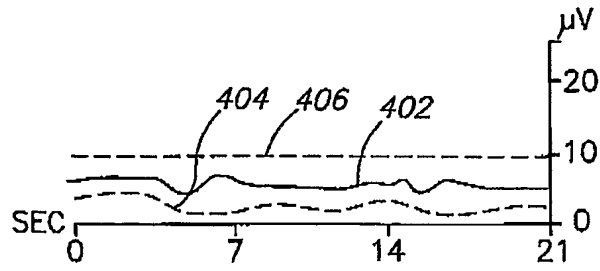

FIG. 5D

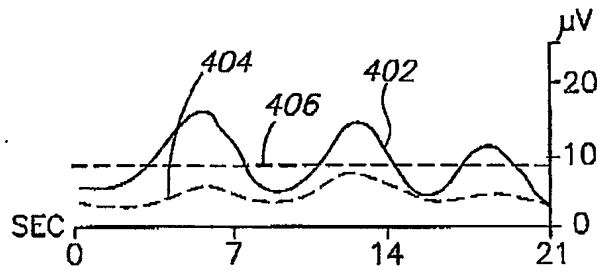

FIG. 5E

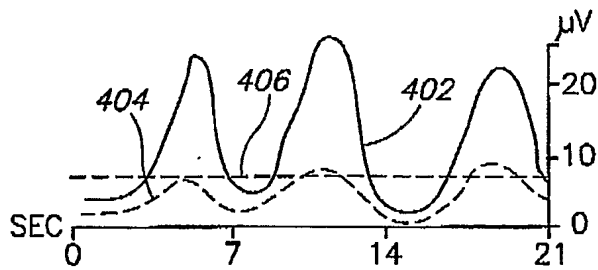

FIG. 5F

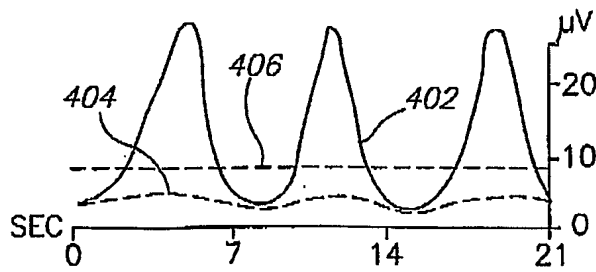

FIG. 5G